

OVERLAND CONVEYORS DESIGNED FOR EFFICIENT COST & PERFORMANCE

Lawrence K. Nordell, President
 Conveyor Dynamics, Inc.
 1111 West Holly Street, Suite A, Bellingham, Washington 98225
 Telephone: 360-671-2200 FAX: 360-671-8450
 E-mail: nordell@conveyor-dynamics.com
Presented at the Bulk India Conference – December 2003

ABSTRACT

India is applying longer and larger belt conveyors to transport her mineral wealth in record amounts, rivaling Australia, Brazil, Chile, China, Germany, Russia, and the USA. Is India ready to use advances in bulk handling technology and to get full value for capital expenditure? Do owners look at evaluating Total Life Cycle Cost (TLCC) measured by Net Present Value (NPV) capital, operating, and spares expenditures over the plant life? Are there modern technologies that India's owners and engineers are overlooking? When you look at design criteria issued by major owners and engineering firms, do you see modern advancements? This paper will show that the monetary loss to the owner/operator is staggering when they fail to apply modern techniques and capture opportunity.

Some consultants question, in publications, the veracity or accuracy of these modern techniques while extolling the potential benefit. We show greater than 96% accuracy repeatable in: a) measurements of rubber properties; b) field measurements; and c) comparison between theory and practice. We publish our results. Therefore, I say they are incorrect in stating that manufacturing errors, incomplete theory, and field measurement errors cannot produce conclusive theoretical results beyond 70% certainty.

INTRODUCTION

The world spends about \$2 billion USD annually on new and replacement belt conveyors for bulk material handling. When factored for total belts in use, this represents 30-40 billion kW-hrs per year.

Prudent design can reduce Total Life Cycle Cost (TLCC), equipment and operating cost, by 30-40%, depending on the installation configuration calculated at Net Present Value (NPV).

This technology meets the Kyoto Protocol philosophy, saves significant capital, offers additional capacity and profit, and leaves a legacy for the next generation of like-minded engineers.



Fig. 1 Warkworth overland negotiating obstacles using a low profile hood cover - Australia

KEY AREAS OF IMPROVEMENT

Traditionally, belt conveyors have been notoriously over-designed. Fifty-year-old engineering design standards and methods are still being applied today. The use of these standards results in substantially higher capital (CAPEX) and operating (OPEX) costs when compared with those incorporating today's technical advancements.

Key overland technologies render historical design standards, used throughout the world, overly conservative and archaic. Historical standards include: CEMA (Conveyor Equipment Manufacturers' Association), DIN 22101 (Deutsche Industrial Norm for Belt Conveyors – August 2002), and ISO 5048-1989 (International Organization for Standards – February 2000).

Key overland technologies include:

1. Power Analysis / Rubber Rheology / Understanding Benefits / Verifying Results
2. Idler Spacing Optimization and Low Mass Supports
3. Belt Safety Factor to 5:1
4. Head / Tail Drives / Booster Drives / Power Strip
5. Eliminating Transfer Stations using Horizontal Curves – Refer to Fig. 1
6. Belt Life, Puncture Prevention; Dust Control-Transfer Chute Design
7. Dynamics & Control

These technologies do not exhaust the engineer's toolbox. They are only indicative of the many initiatives that produce meaningful savings. Significant questions still beg to be addressed. Some of these are:

1. How long can we make one flight, or when do we make more than one flight
2. Idler trough shape optimization
3. Optimal idler support based on mass per length and on vibration control
4. Idler roll diameter, bearing size, spacing optimization while controlling belt edge flap

POWER CONSUMPTION / RUBBER RHEOLOGY

Belt conveyors consume power from belt bottom cover deformation over the idler rolls and from idler drag losses, in addition to drive inefficiencies and gravity lift forces. Viscoelastic rolling resistance from belt cover in contact with the idler rolls and belt flexure between idler sets is responsible for 50-70% of most long overland conveyors' power consumption (1,2,3,4).

For more than a decade, belting manufacturers have been substantially improving belt cover rubber technology. This has resulted in new low rolling resistant rubber (LRRR) compounds that are now commercially available to the consumer from many producers. Power analysis, using rubber viscoelastic mechanics, can reduce power consumption by up to 50% over published methods, such as CEMA and DIN. New and aged rubber can be studied for additional benefits.

Historical power analysis methods use 5 empirical factors to specify the 1950's CEMA rolling resistance coefficients. No regard is given to rubber type, rubber thickness, idler roll diameter, trough shape, belt speed, temperature above zero degrees Celsius, belt construction, or vertical and horizontal curve pressures, to name a few of the oversights. This equation is for the **ky** contribution only, per Fig. 2a.

Over 15 years ago CDI developed a +17 attribute theoretical power equation that includes the viscoelastic behavior of the conveyor cover rubber compounds (3). This method is compared with CEMA and with DIN 22101. Fig. 2a illustrates a schematic of the rolling resistance coefficient found in the CEMA and DIN 22101 power calculation procedures. Fig. 2b illustrates ore and belt induced pressure gradient in contact between belt and idler viewed from the idler's trough cross-section. Fig. 2c illustrates idler roll and belt's rubber cover deformation and contact reaction forces in a cross-sectional view at the idler diameter, due to pressure distribution shown in Fig. 2b. Fig. 2c schematically demonstrates the imbalance of rolling resistance forces (F_1 ; F_2) and change in the moment arm (a_1 , a_2) between the belt's rubber elastic compressive deformation zone and the rubber's elastic recovery zone. Also included in the model are sag geometry related losses due to belt flexure and ore agitation between idlers (Fig. 2d).

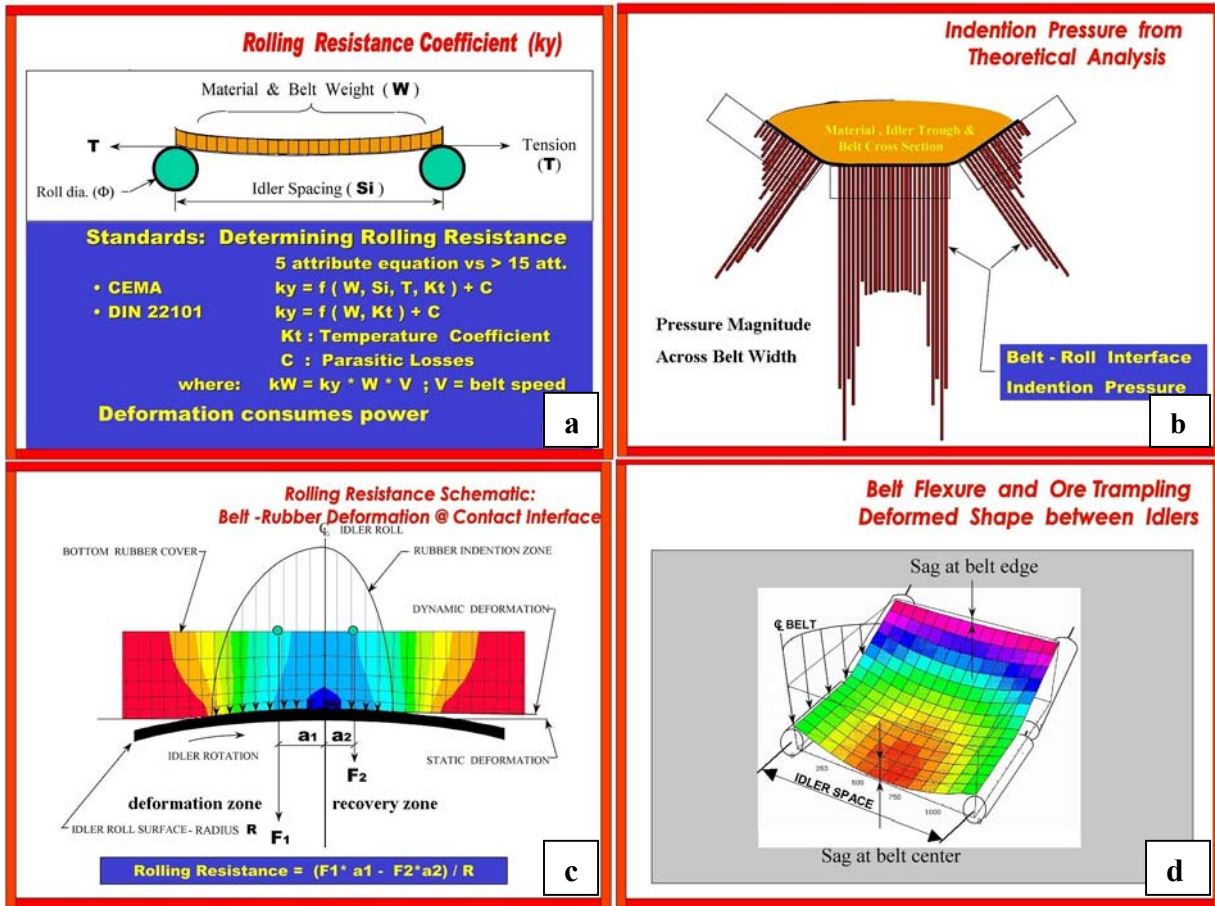

Fig. 2 Rolling loss schematic at idler interface with belt, as shown on these four figures.

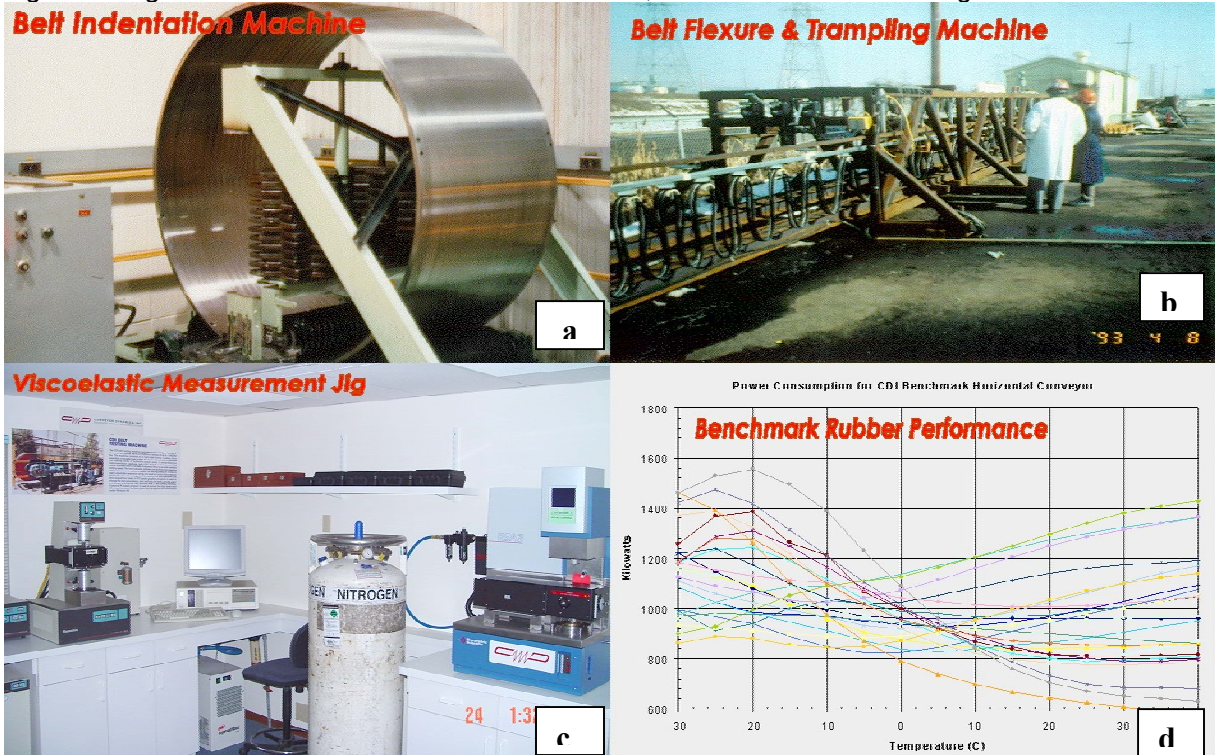

Fig. 3 Belt indentation test machine, belt flexure and trampling test machine, viscoelastic measurement test machine, benchmark rubber performance graph

Fig. 3a is a photo of the belt indentation testing machine used to verify the mechanics of Fig. 2c. A full belt width, of up to 1800 mm, can be tested. Belt is inserted inside the drum and secured with either belt cover facing the idler. One idler roll, of various sizes and constructions, is held normal to the drum's rotation, and jugged to contain the various weights that represent up to 20,000 t/h with the speed adjustment. The drum is rotated on support rolls, which can spin the drum up to 10 m/s surface speed. The drum can be placed into a cold chamber to vary the temperature down to -40°C and up to 150°C .

Fig. 3b is a photo of the belt flexure and material trampling test machine verifying Fig. 2d.

Fig. 3c shows the rubber properties testing laboratory that includes two Dynamic Mechanical Analyzer (DMA) machines.

Fig. 3d graphs 23 rubber compounds that benchmarks their individual power performance ratings verses temperature. Note the large spread in kW values with extremes of temperature. Low temperature behavior has a direct and proportional equivalence to high speed behavior.

This technology allows the engineer to optimize the system components at the design stage. By incorporating low rolling resistance rubber compounds, major components of the system can be optimized. Reduced motor sizes, lower belt strength and covers, and lighter structural loads are a few of the items that can produce substantial capital cost savings.

POWER ANALYSIS – UNDERSTANDING BENEFITS

A hypothetical 5 km overland is used to demonstrate the rolling resistance and belt strength selection difference between the CEMA Standard design method and the alternative viscoelastic theory. The differences are measured in CAPEX (capital expense) and OPEX (operating expense) costs.

The conveyor is design with CEMA and with viscoelastic power equations at three yearly productions, which are 6, 12 and 18 MMT/year loads. The three loading levels equate to 1000, 2000, and 3000 mt/h. The conveyor designed with the viscoelastic power equation assumes a low rolling resistant rubber is used on the bottom cover of the belt. This example illustrates the potential savings in both CAPEX and OPEX in designing a conveyor with a low rolling resistant rubber.

As illustrated in Figure 3d, not all rubbers are equal. A low rolling resistant compound can result in up to 60% less power consumption over a "off the shelf" rubber.

The following standard criteria, referred to as "Common Practice", are used in the conveyor design example:

- a) Idler Spacing: 1.5 m (4.93 ft) carry; 4.5 m (14.8 ft) return
- b) Belt Speed: 4.5 m/s (886 FPM)
- c) Belt Width: allow for +100 mm edge clearance
 - 1000 t/h = 900 (35.4") mm
 - 2000 t/h = 1200 (47.2") mm
 - 3000 t/h = 1500 (59.1") mm
- d) Belt Safety Factor: SF=6.5:1 breaking: operating strength ratio
- e) Idler Bearing Selection: >60,000 L10 hours; 152 mm diameter

The conveyor with the low rolling resistant rubber on the bottom cover is design with modern design criteria, referred to as "Best Practice". Best Practice standards are:

- a) Idler Spacing: 3 m (9.84 ft) carry; 9 m (29.f ft) return
- b) Belt Speed: 5.5 m/s @ 1000 t/h
6.2 m/s @ >1000 t/h
- c) Belt Width: 1000 t/h = 800 (31.5") mm
2000 t/h = 1050 (41.3") mm

- 3000 t/h = 1200 (47.2 ") mm
- d) Belt Safety Factor: SF=5.5:1
- e) Idler Bearing Selection: >100,000 L10 hours; 152 mm diameter

CAPEX and OPEX tables are given for 3 tonnage cases. The cost summary is for belt, idlers, and drive assemblies only. Comments on savings refer to potential lower cost going from "Common Practice" to "Best Practice." The last table shows the percentage of OPEX that is derived from power and idler replacement costs. The remaining OPEX costs are not included.

<u>CAPEX</u>	<u>6 MMT/y</u>	<u>12 MMT/y</u>	<u>18 MMT/y</u>
<i>LRRR/CEMA (Savings)</i>	40%	35%	31%
<i>CEMA/LRRR (Penalty)</i>	66%	53%	45%
<u>OPEX 15-y NPV @ 6% rate</u>	<u>6 MMT/y</u>	<u>12 MMT/y</u>	<u>18 MMT/y</u>
<i>LRRR/CEMA (Savings)</i>	40%	37%	33%
<i>CEMA/LRRR (Penalty)</i>	67%	58%	49%
<u>%OPEX that is Power Cost</u>	<u>6 MMT/y</u>	<u>12 MMT/y</u>	<u>18 MMT/y</u>
CEMA	88%	94%	96%
LRRR	88%	84%	92%

Fig. 4 shows CAPEX and OPEX cost savings for LRRR (low resistance) rubber compared to the CEMA design. In summary, as a typical benefit going from "Common Practice" to "Best Practice", the following benefits are observed for 12 MMT/y:

<u>Attributes</u>	<u>CEMA</u>	vs.	<u>Rubber Viscoelasticity (LRRR) % Improvements</u>
Avg. Power Difference	100%		60% reduction from CEMA standard
Strength	100%		63% reduction from CEMA standard
Belt Speed	4.5 m/s		138% @ 6.2 m/s
Idler Spacing	1.5 x 4.5		200% @ 3 m x 9 m
Belt Strength SF	6.7:1		82% @ 5.5:1
Belt Width	1200 mm		67% or 800 mm
Capital Cost Saving		>35%	LRRR/CEMA
Operating Cost Saving		>37%	LRRR/CEMA @ \$0.030/kW-hrs/y Industrial cost of power
Total Cost Saving 15-y NPV		>35%	LRRR/CEMA

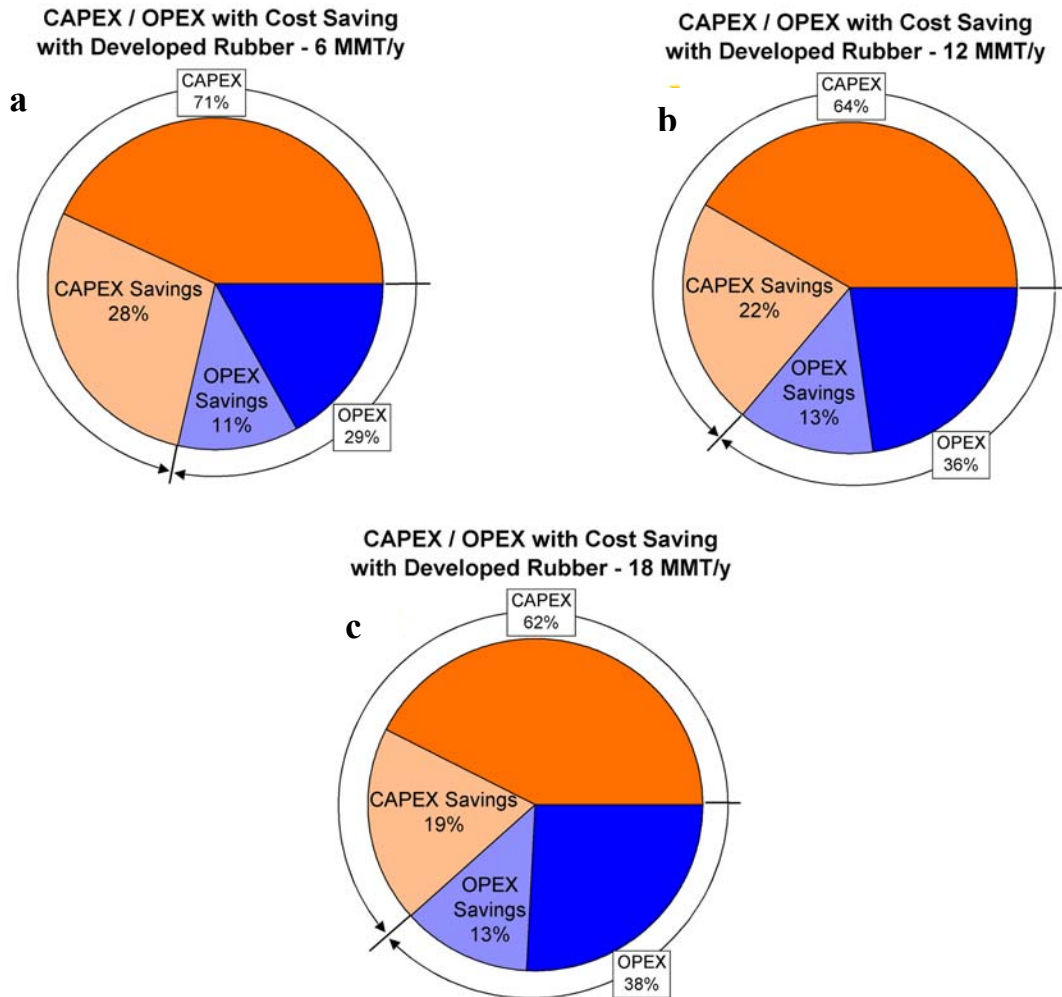

Fig. 4 - CAPEX / OPEX with Cost Saving with LRRR (Low Rolling Resistance Rubber)

World Electric Power Savings Potential: 15-20 billion kW-hrs/y

VERIFICATION

The above improvement claims are verified by many measured large overland systems greater than 6 km. Typical examples of conveyor systems designed and optimized by CDI are shown in Fig. 5:

- Fig. 5a 1989 Channar, Australia – 20.5 km; lowest published rolling friction worldwide
- Fig. 5b 1995 ZISCO, Zimbabwe – 16 km; long booster drives; large idler spacing
- Fig. 5c 1998 Muja/Collie, Australia – 14 km; low profile, lightweight stringers
- Fig. 5d 2000 CRU-II Project, South Africa – 8.8 km; low profile, lightweight stringers

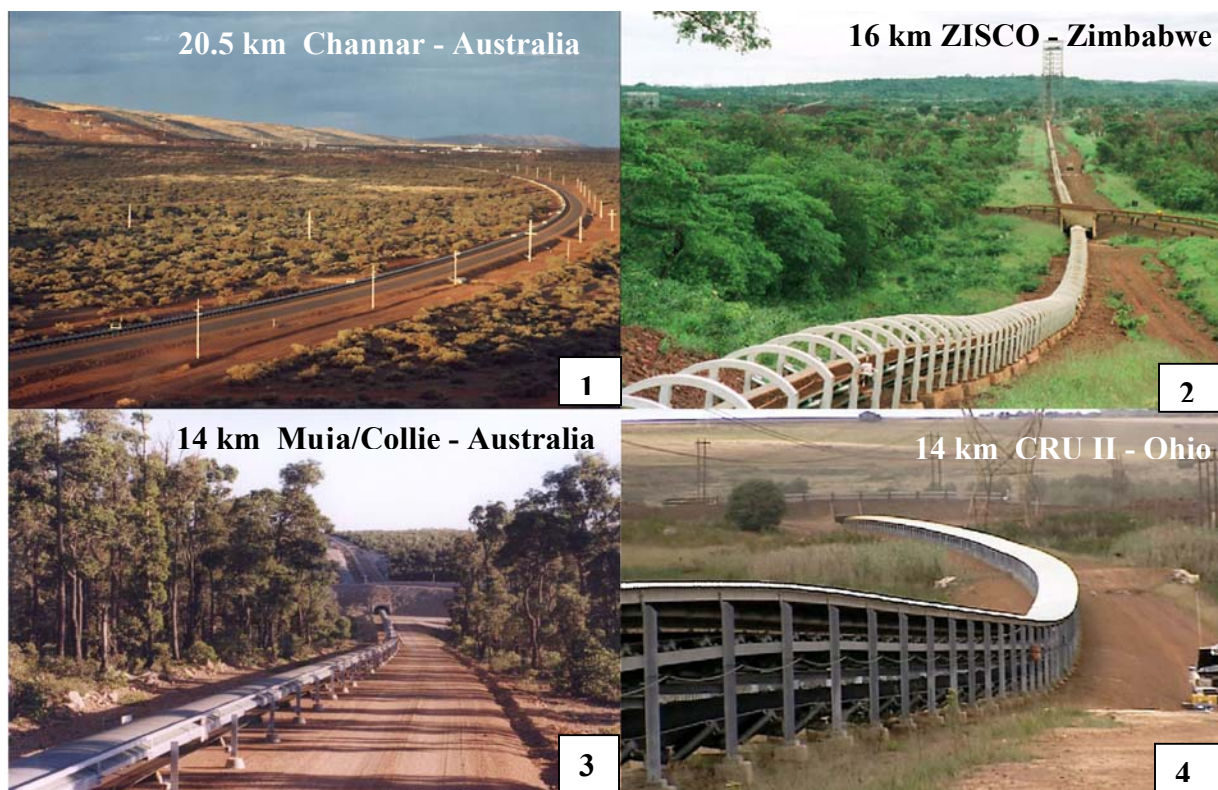

Fig. 5 Illustrates four overlands

Verification of this technology is ongoing. We offer two examples of conveyors where field measurements validate the theory.

- Example 1: 1989 – Channar, Australia – 20.5 km; Channar has worlds lowest rolling resistance power per ton per mile with a DIN $f = 0.0085$ (CEMA minimum $f = 0.016 + \text{idler losses}$). Theory and practice have better than 95% correlation index.
- Example 2: 1996 – ZISCO, Zimbabwe – 16 km; ZISCO, 1996, was world’s longest single flight troughed conveyor. The theory and practice have better than 95% correlation index.
- Example 3: 1998 - Muja, Australia – 6 km; CEMA vs. Rubber Rheology (Reference Fig. 5c above) Fig. 6a illustrates CEMA and CDI theoretical power prediction versus measured power over a range of tonnages. Using LRRR, the theory and practice have better than 98% correlation index.
- Example 4: Designed 1972 and measured 2000 - Southern Ohio Coal, U.S.A. – 7 km Fig. 6b shows power vs. tonnage for CEMA and two rubber compounds with tonnage 0-2000 stph. Goodyear commissioned CDI to measure conveyor power draw with an older compound and then remeasure the same conveyor with a new improved compound. Note, CEMA does not differentiate between rubbers. The only change to the conveyor was the alteration of the bottom cover compound (carry and return idler and pulley contact – the belt has turnovers). Here we see a 20% reduction in power between rubbers and 24% reduction below CEMA. Stated as a penalty for use of an inferior rubber, this means that power consumption is increased 26% when using the inferior compound. The conveyor was designed in 1972. Improvements to the 1972 design would yield further benefits. The theory and practice have better than 95% correlation index.

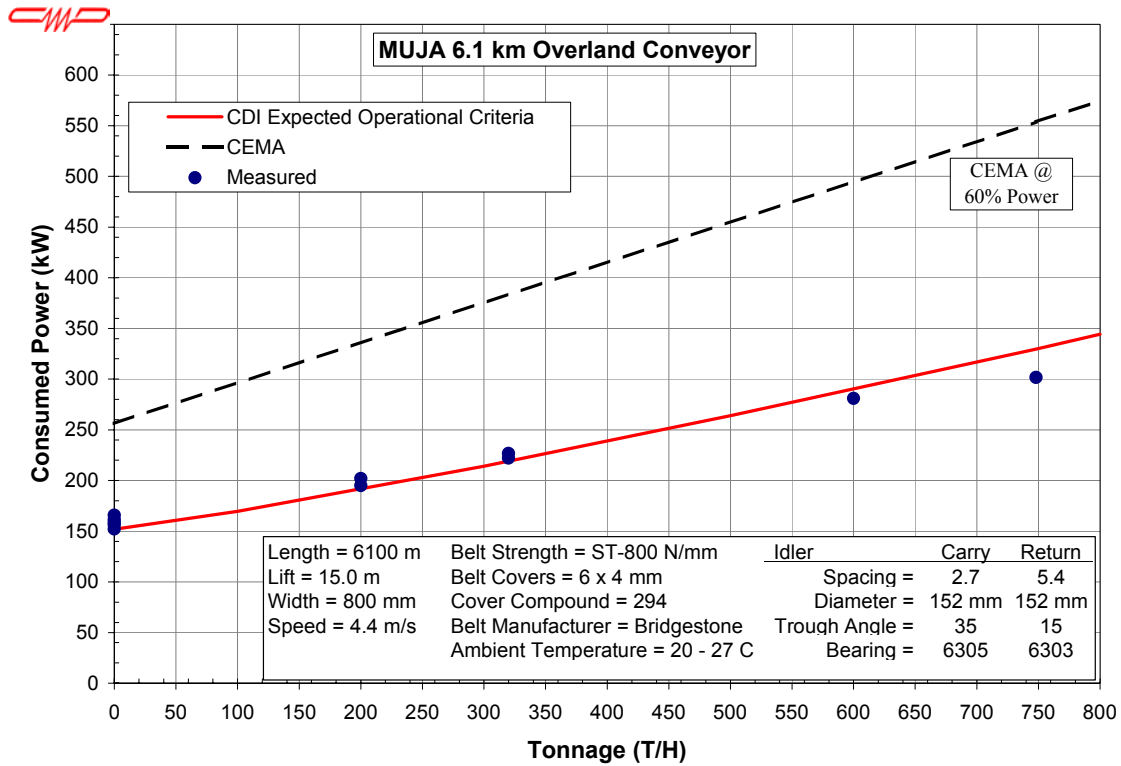

Fig. 6a - Power Measurements at Muja, Australia

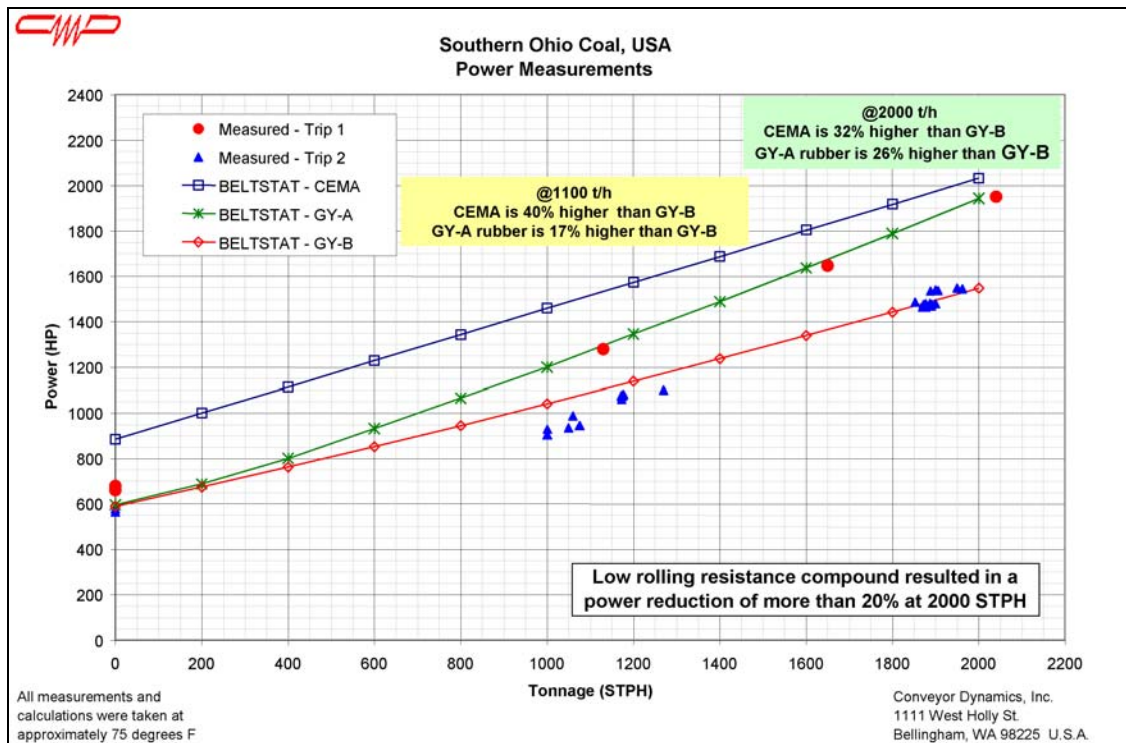

Fig. 6b - Power Measurements at Southern Ohio Coal

IDLER SPACING OPTIMIZATION

Idlers have a significant impact on capital cost, operating cost, and maintenance level of a conveyor. Idler optimization was implemented on the BHP-DRI, Australia bi-way 7 km overland conveyor, shown in Fig. 7a. The results of this study show the importance of idler optimization. This overland conveyor carries ore at 4000 t/h on the carry strand and up to 1000 t/h at +100°C on the return strand simultaneously. In general, excepting idler drag, power consumption increases as idler spacing increases and decreases as the idler diameter increases. Larger idler spacing reduces the capital cost of the conveyor. Fig. 7b shows the demand power for 152 mm and 178 mm idlers for an idler spacing ranging from 1.5 m to 2.5 m. There is a 12% increase in power for increasing the idler spacing by 1 m. Figures 7c, 7d, and 7e show the power, capital, and idler replacement cost as a function of idler spacing. Fig. 7f shows the total conveyor NPV cost, including power, initial idler cost, and idler replacement cost. Idler spacing was not increased further due to belt construction limitations.

Since power cost increases and capital cost decreases with idler spacing there is often an optimal idler spacing where the two factors produce the minimum Net Present Value (NPV). In the example, this is seen with the 6305 bearing series where the optimal idler spacing is at 2.25 m. If the idler spacing, in the example, were extended to 4 meters, a similar optimal spacing would be present for the 6306 and 6308 bearing idlers, except as noted for belt construction limitations above.

Other factors must be considered in the selection process, including:

1. Idler support steel and harmonic model compliance
2. Noise, belt, and structural vibration
3. Belt construction limits at idler junction

Generally speaking, operators, design, and construction companies are only concerned with the capital cost of the conveyor. However, idler optimization that includes effect on power consumption and equipment selections together, with the other noted considerations, can lower the Total Life Cycle Cost of the conveyor by a significant margin as is shown. Noted NPV cost are for 15 years.

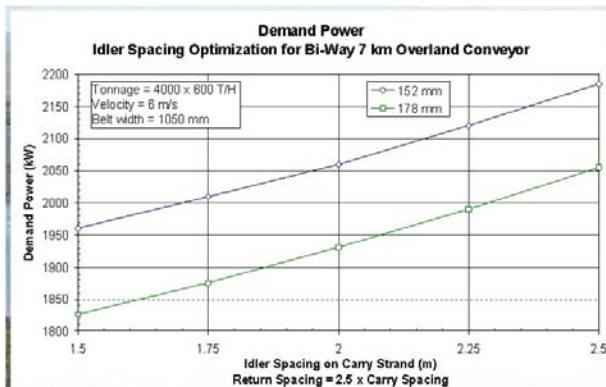

Fig. 7b Demand Power vs Idler Spacing & Roll Diameter

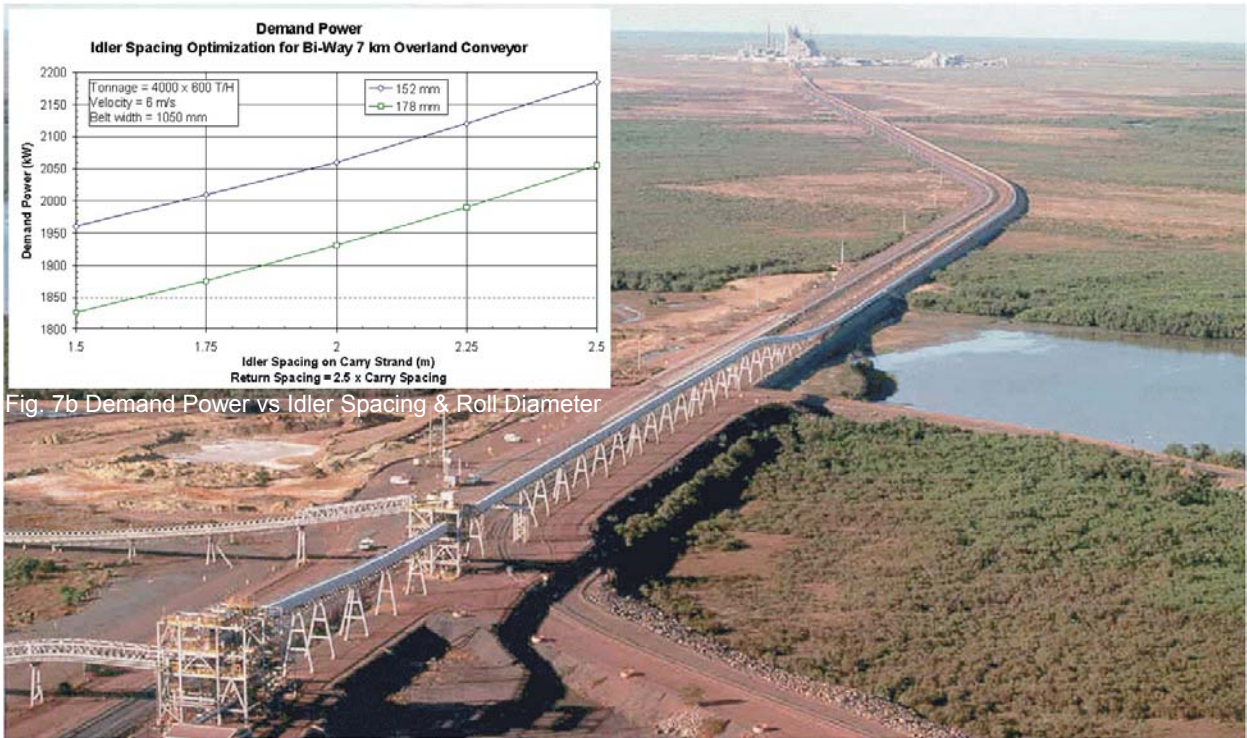

Fig. 7a 7-km BHP-DRI bi-way transport at 4000 t/h iron ore x 1000 t/h hot briquette

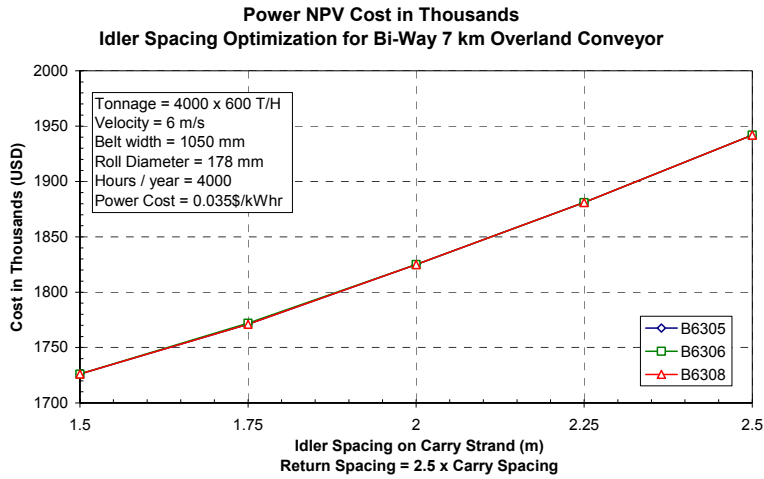

Fig. 7c Power Cost vs Idler Spacing

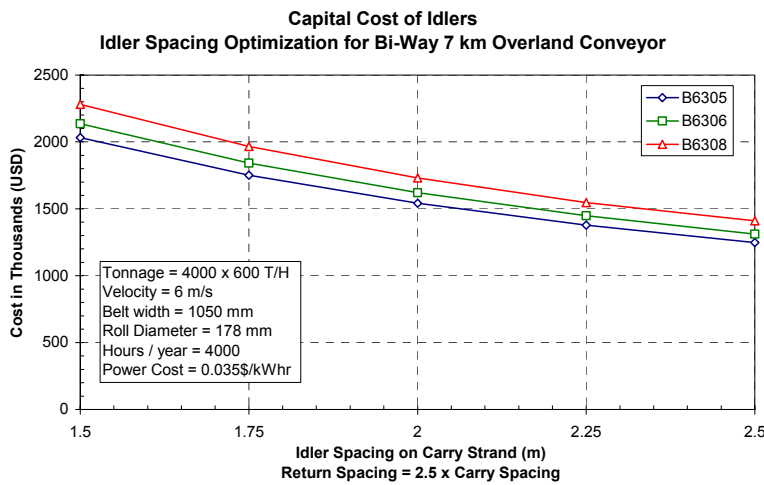

Fig. 7d Capital Cost of Idlers vs Idler Spacing

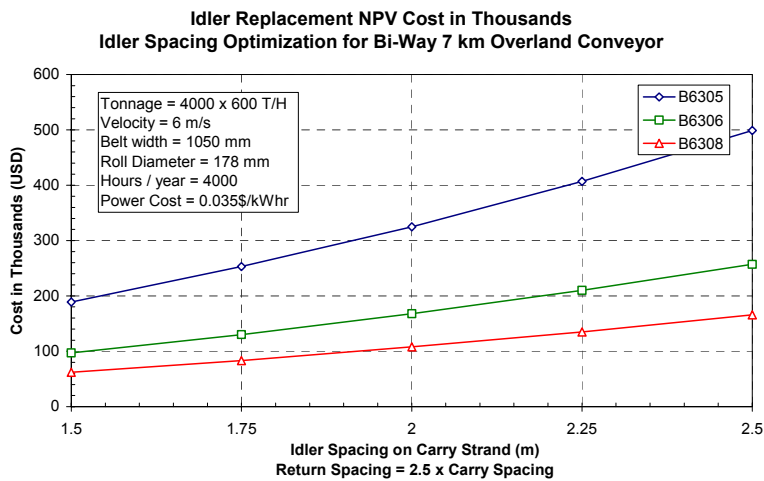

Fig. 7e Idler Replacement Cost vs Idler Spacing

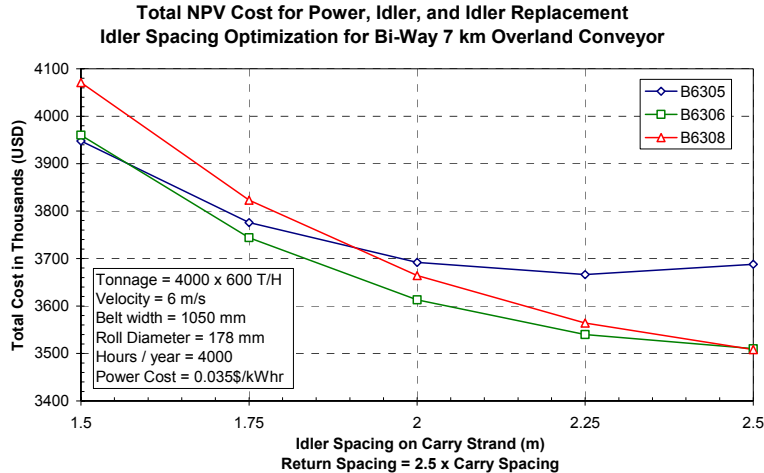

Fig. 7f Total Cost (including NPV) vs Idler Spacing

BELT STRENGTH AND SAFETY FACTOR

Splice dynamic strength governs the belt strength rating. Combining power and splice strength benefits can result in +25-50% reduction in strength rating. Modern splicing techniques and test verifications are well known (5,6;7) . We strive to continue lowering the safety factors below 5.5:1. This can be unwise without knowing the significance of the manufacturer's product aging and long-term dynamic strength. Testing new belt may demonstrate the ability to lower the safety factor well below 5.5:1. However, it does not give good knowledge of aged belts. Aging studies of core gum splice rubber are now ongoing. New compounds and methods are under study to enhance aged dynamic strength. Building a splice with aged belt, in service for more than 8 years, shows a lowering of the dynamic splice strength by 50% or more. Once an aged belt splice has failed, it should be retested to determine if an alternate splice procedure should be used to gain back lost strength. Compound performance differs with location such as hot, dry vs. cold, wet environments.

HEAD AND TAIL DRIVES

Correct drive placement is an important part of good conveyor design. Cost can be reduced and design improved by optimizing drive placement in conveyors and especially so in long overlands. Drive placement optimization of an overland conveyor requires input from the conveyor's vertical and horizontal alignment. In conveyors where lift is not the controlling factor, it is often beneficial to place a drive at the tail of the conveyor, in addition to the head drives. The purpose of a tail drive is to drop the tension thereby reducing belt strength. This may be essential for conveyors with vertical and horizontal curves. Drive placement and curve size limitations lead to excessive civil works, or force the conveyor to exceed property right-of-ways.

As an example, CDI designed the 15.6 km overland conveyor for the 1995 ZISCO project in Zimbabwe. This conveyor is built with a head and tail drive. Fig. 8 shows the tension profile of this belt with the as built tail drive (solid line) and the resulting tension if the tail drive were not installed (dashed line). Without the tail drive, belt tension would increase 46% at the head end. The conveyor is installed with a ST-888 N/mm belt. However without a tail drive, the required belt rating is ST-1300 N/mm (46% higher). Obviously, the reduced belt strength and drive system was a significant CAPEX savings. Further, the ZISCO belt has a horizontal curve over 30% of the belts length. The horizontal curve starts at station 1160-m and ends at 5710-m. The horizontal curve would be more difficult with the larger tension range if not for the tail drive.

15.6 km Overland Conveyor at Zisco Drive Optimization

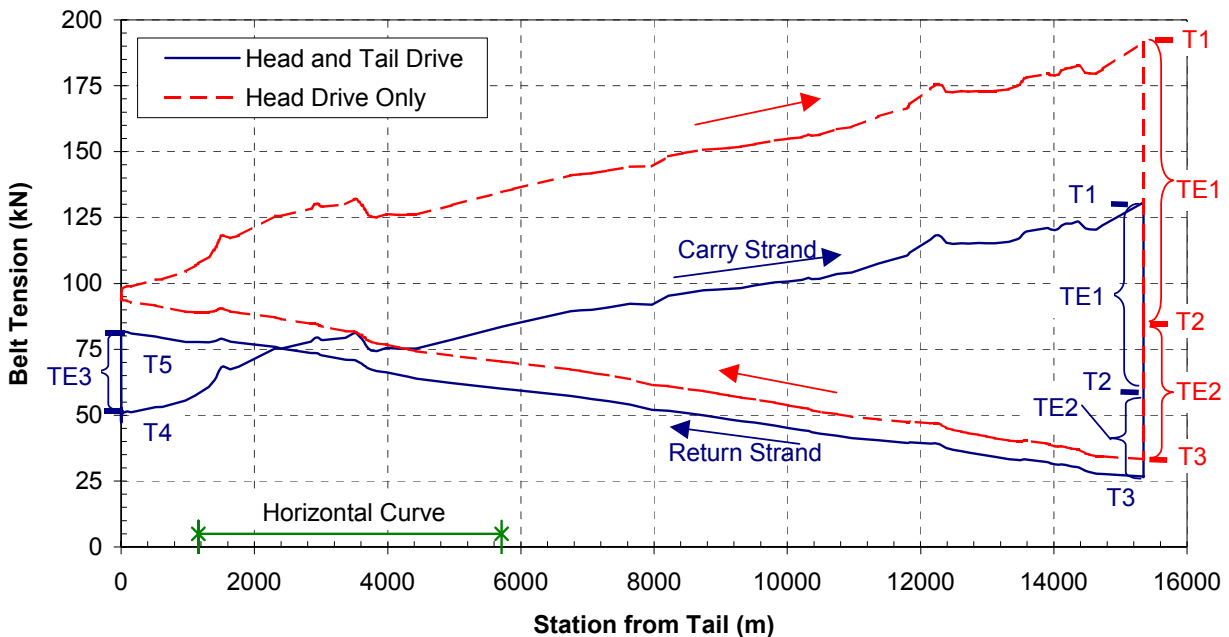

Fig. 8 Belt optimization for head & tail drive tension comparison

HORIZONTALLY CURVED OVERLAND – ELIMINATING TRANSFER STATIONS

Many engineers design horizontally curved overland conveyors today. The main benefits are eliminating transfer stations and multiple flights. Each additional flight:

1. Reduces belt life by multiplying the wear rate generated by the transfer
2. Reduces conveyor availability or total throughput by about 1% per conveyor
3. Increases CAPEX and OPEX costs
4. Increases maintenance and downtime to repair transfer equipment and extra pulleys, turnovers, etc.
5. Increases risks of belt damage and the consequences from tears, punctures, fires, et al.
6. Increases fugitive ore carryback and decreases return idler life
7. Decreases power efficiency. Each 1000 t/h transferred requires about 4.5 kW to accelerate the material 4 m/s. and 10 kW to bring each 1000 t/h to 6 m/s.
8. Eliminates transfer sequential flow control required to simultaneously regulate stopping.

BELT LIFE & TRANSFER CHUTE DESIGN

Transfer loading points produce abrasive belt wear and put the belt at risk to puncture, gouging, tear and fire damage. Over 95% of a belt's cover wear life can be attributed to poor transfer chute designs.

Coal lump degradation, fugitive dust, fire, noise, spillage, belt tracking errors, pulley damage, splice damage, idler and skirtboard damage, and belt damage under the skirts can be blamed on poor chute design. Fire and black lung are major hazards in coal transport. Control of gas dynamics in chutes will lead to improvements in dust control and its concomitant results.

Today these undesirable factors can be mathematically analyzed, and new chute shapes, with better flow and liner wear properties can be selected based on first principle physics. The new analysis technique is called DEM (Discrete Element Method) (8). By incorporating this technology, belt cover thickness can be reduced to a fraction of typical specifications, while increasing total belt life. Degradation, dust, noise, tracking, et al. are improved.

Belt life can be increased to exceed 20 years of service even in extreme conditions, such as at the Palabora mine in South Africa. The original 6000 t/h, 1800 mm wide, 15-degree slope belt wore out in less than three years. A new curved chute was installed in 1994 (9;10). Wear measurements over the last nine years have projected the wear life to exceed 20 years (predicted at 25-30 years). This is shown in Fig. 9a. Rock colors signify various sizes and non-spherical shapes.

Fig. 9b illustrates multiple rock box ledges redirecting, dropping high tonnage (10,000 t/h) copper ore and centering the load onto the receiving belt. Color gradient indicates velocity changes with blue slowest and red highest. The chute is in design.

Fig. 9c illustrates the combination of a rock box and curved chute and change in direction with high tonnage (8700 t/h) and speed (6m/s) implemented at the Los Pelambres mine in Chile, 1999.

Fig. 9d illustrates control of coal flow to minimize degradation and dust generation. Velocity is controlled to minimize particle collisions and gas entrainment. Other restrictions were imposed on this existing transfer, including tripper travel that limited options.

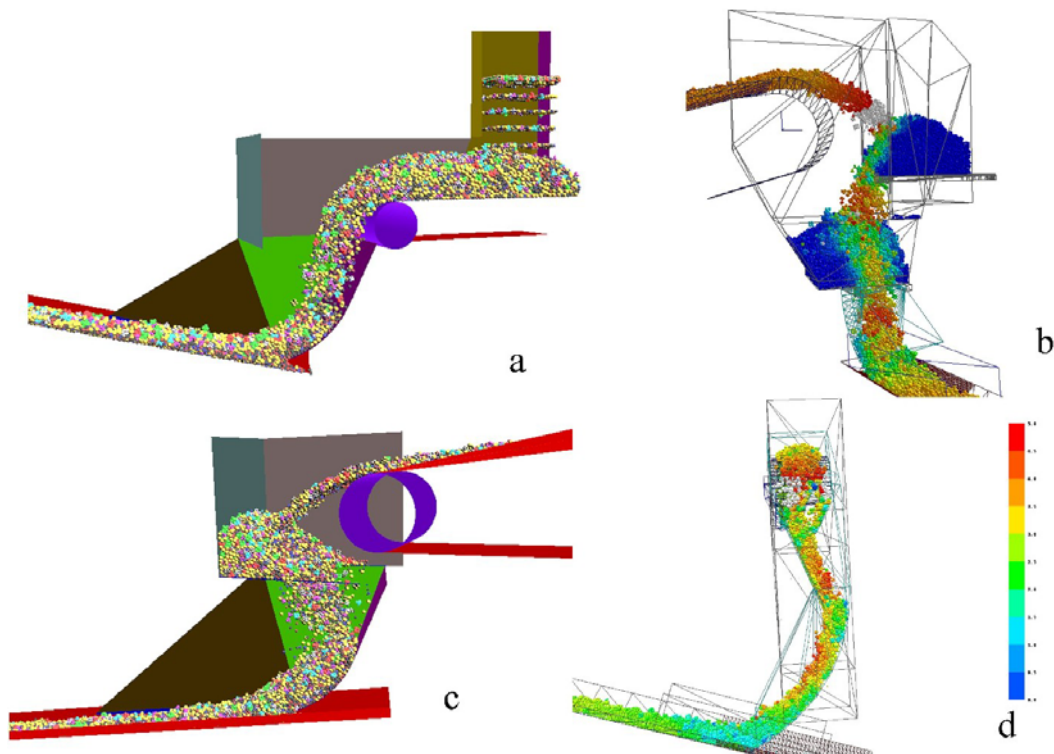

Fig. 9 - Granular flow in various chute configurations

DYNAMICS & CONTROLS

The current CEMA, DIN, and ISO dynamic analysis calculation procedures are very crude, or entirely nonexistent. No attempt is made to understand the true dynamic behavior of the belt. This “unknown” factor results in increased belt ratings and structural design loads, power consumption, and increased risk to the entire conveyor system. The potential for error is significant for overloads.

In order to optimize the system design, a thorough knowledge of the dynamic behavior of the belt is required. Dynamic analysis uses two dimensional shock wave theories to calculate time dependent transmission of large local force and displacement disturbances along the belt that result from a quick change in local belt tensions, such as starting or stopping a drive or applying a brake (11,12;13). The first dimension refers to axial displacement. The second dimension refers to the vertical displacement between idler sets that we first published in 1984 (11). The belt is divided into a series of elastic springs

and masses that deform along the belt's axis. Simulation is based on a lumped mass and spring model with non-linear damping (Fig. 10). Powering drives on and off causes a local tension change that travels away from the impulse source at the speed of sound in the belt's tension medium. The shock wave speed can reach 2.5 km/sec in high-tension steel cord cable.

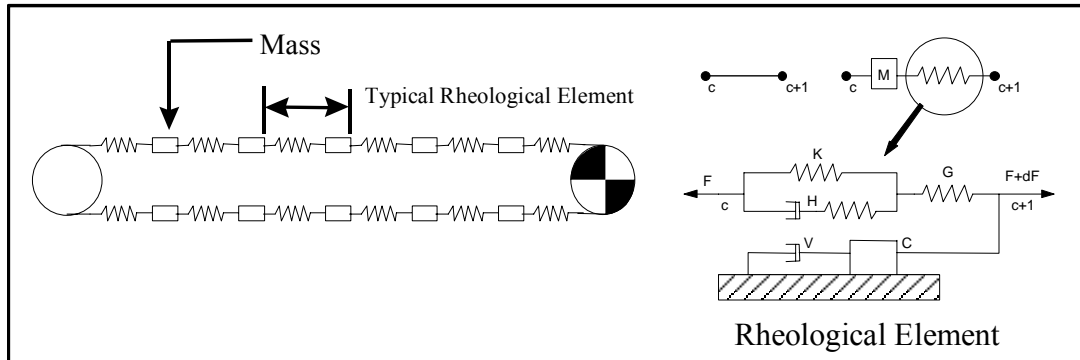

Fig. 10: Example of a finite element representation along the belt w/ its springs and dashpots

Dynamic analysis is used to:

1. Simulate all motor and brake starting and stopping control functions and integrate their independent control methods with the belt's elastic response.
2. Develop control strategies and dynamic tuning methods to limit shock wave forces and belt line displacements to acceptable levels using drive inertia tuning and other methods.
3. Analyze and control the cause and effect resulting from "what if" operation scenarios, such as drive and brake malfunctions.

CDI has incorporated shock wave dynamic analysis into conveyor designs since 1980. A couple of two-dimensional simulations (animations) are presented that highlight difficulties during stopping. Stopping is usually the more difficult due to the near instantaneous loss of power (1-4 seconds) versus the longer period (30-500 seconds) acceleration ramp. Fig. 11 illustrates the aftermath of dynamic forces. The upper photo illustrates collapsing of belt tension, which causes coal to spill at a predictable location along its profile. During starting, the right hand moving belt tends to pull the right hand idler out of its support.

The lower two photos show the result of a starting device that overstressed a weak (poorly designed) steel structural member. The combination produced a 9 million dollar failure. There are many examples, produced around the world, that are not made public. Clients tend to believe the design culprits will commit to a fix if, and only if, the mistake is not publicized.

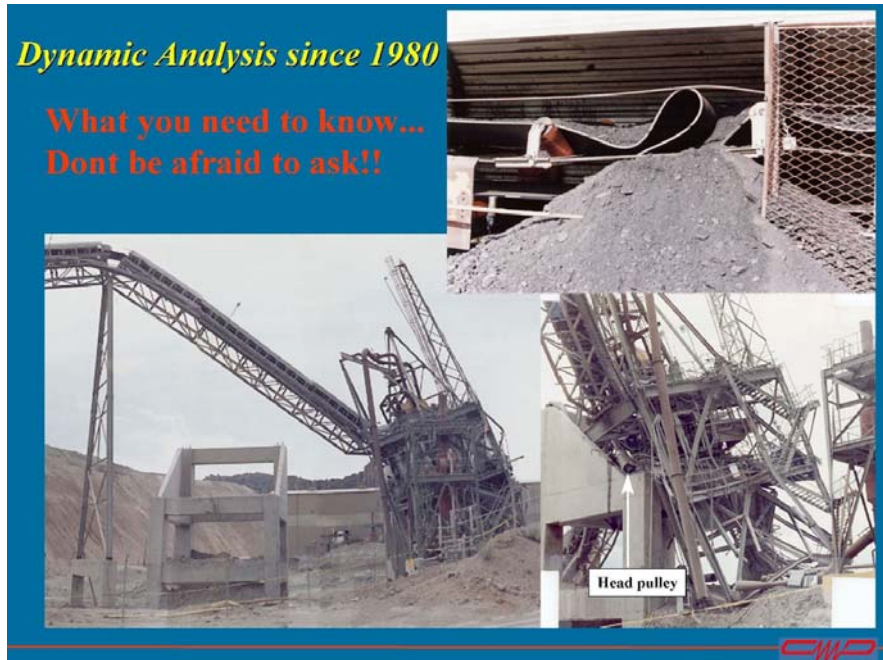

Fig. 11 Structural failure due to large transient tensions during starting

Fig. 12 illustrates a dynamic control instability during starting of the 15.6 km overland conveyor at ZISCO in Zimbabwe. This conveyor is built with a dual head drive and single tail drive as shown in Fig. 12a. The tail drive is the speed master and the head is equipped with a load cell immediately after the secondary drive at the head. The load cell acts in the same manner as a “booster” drive to control the three-head drive acceleration process. The head end load-cell acts as a pseudo take-up. Head drive acceleration is regulated by the load-cell set point and PID algorithm.

The conveyor design was optimized with dynamic analysis. During commissioning, the startup had velocity control instabilities between the head and tail drives shown in Fig. 12b. This regulation algorithm was implemented by the manufacturers. Belt vibration, such as shown in 12b, can lead to reduced belt and conveyor equipment life and produce hazardous operating conditions. The control instability was removed by CDI dynamic regulating algorithms, synchronizing the head with the tail drive as shown in Fig. 12c.

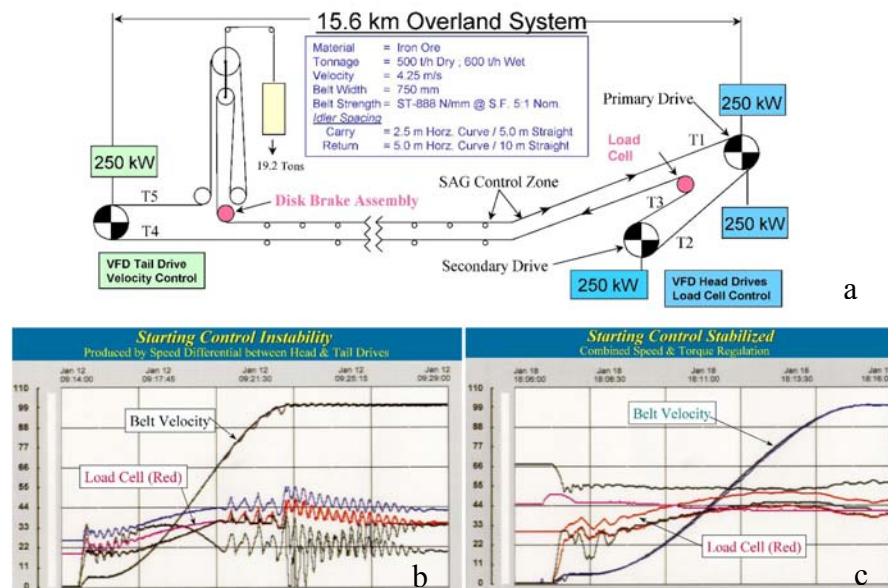

Fig. 12 Instable and stable starting controls of 15.6 km overland conveyor

VISCOELASTICITY ANALYSIS AND APPLICATIONS - OBSTACLES TO ACCEPTANCE

Viscoelasticity power analysis methods are not published or in the public domain. This has led to resistance to using these procedures. Engineers do not want to contract for the services when they can not define the benefits or understand the analytic procedures. Germany and The Netherlands have pursued the potential since Spaan's publication in 1978 and Jonker's paper in 1980.

CDI developed the formulation in 1988 and has made ongoing improvements in theory and measurements. Over one million dollars was invested to develop the procedures and verify their accuracy. A three-year study with Syncrude Canada Ltd. confirmed the theory, and included many laboratory and field tests (3).

CONCLUSION

In summary, significant benefits can be derived from the key technologies that are available today, but which are not commonly practiced.

1. Understanding viscoelastic rubber analysis properties and their influence on the power analysis equations on CAPEX and OPEX
2. CAPEX and OPEX savings can each exceed 30 percent over conventional design practices
3. The potential reduction in the World's electric bill, may well exceed 7 billion kW-hours / year when fully implemented
4. Dynamic analysis is a tool that can improve safety and reduce risks in the design of modern overland and high-lift conveyors
5. Modern chute designs can improve environmental compliance eliminating dust emissions, noise, and belt damage, yielding 20-year plus life expectancy

Owners, operators, their purchasing agents, and pro-active engineers can initiate interest where the standards will follow. The potential greenhouse gas reduction benefits are significant.

Several key optimization areas have been discussed and verified as shown by field measurement in many places around the world. **It is now up to owners and operators to take the next step to insure this technology yields the results promised.**

REFERENCES

1. Nordell, L. K., "The Channar 20km Overland, A Flagship for Modern belt Conveyor Technology" *Bulk Solid Handling*, Vol. 11, November, 1991.
2. Hager, M. and A. Hintz "The Energy Saving Design of Belts for Long Conveyor Systems" *Bulk Solids Handling*, Vol. 13, November, 1993.
3. Nordell, L. K., "The Power of Rubber – Part 1" *Bulk Solids Handling*, Vol. 16, July, 1996.
4. Nordell, L. K., "Improving Belt Conveyor Efficiencies: Power, Strength & Life, with Overland System Case Studies" 4th Annual Optimizing Conveyor Performance in Mining Conference, Australasian Mining & Energy Taskforce, April, 1998).
5. Nordell, L., Qiu, X. and Sethi, V., "Belt conveyor steel cord splice analysis using finite element methods" *Bulk Solids Handling*, Trans Tech Publications, Vol. 11, No. 4, pp. 863-868, 1991.
6. Nordell, L.K., "Steel Cord Splice Design and Fabrication Techniques", Paper presented at AIME-SME Annual Convention Reno, Nevada, February 1993.
7. Nordell, L.K., "Steel Cord Belt & Splice Construction: Modernizing Their Specifications; Improving Their Economics" *Bulk Solids Handling*, Trans Tech Publications, Vol. 13, No. 4, November 1993, pp. 685-693.
8. Kruse, D.J. "Conveyor Belt Transfer Chute Modeling and Other Applications using the Discrete Element Method in the Material handling Industry" SME Annual Convention, February, 2000
9. Nordell, L. K., "Palabora Installs Curved Transfer Chute in Hard Rock to Minimize Belt Cover Wear: *Bulk Solids Handling*, Vol. 14, December, 1994.
10. Nordell, L. K. and J.J. VanHeerden, "Technological Innovations Extend Life of Palabora's Main Slope Belt" BELTCON 8 Conference, October, 1995..
11. Nordell, L. and Ciozda, Z., "Transient Belt Stresses During Starting and Stopping: Elastic Response Simulated by Finite Element Methods" *Bulk Solids Handling*, Trans Tech Publications, Vol. 4, No. 1, pp. 93-98, March 1984
12. Nordell, L.K., "The Theory and Practice of Belt Conveyor Dynamic Analysis" BELTCON 4 Conference, September, 1987
13. Kruse, D.J., "Optimizing Conveyor Takeup Systems Using Dynamic Analysis and Implementation of Capstans" SME Annual Conference, February, 2002.